

# Laboratory Ventilation Systems

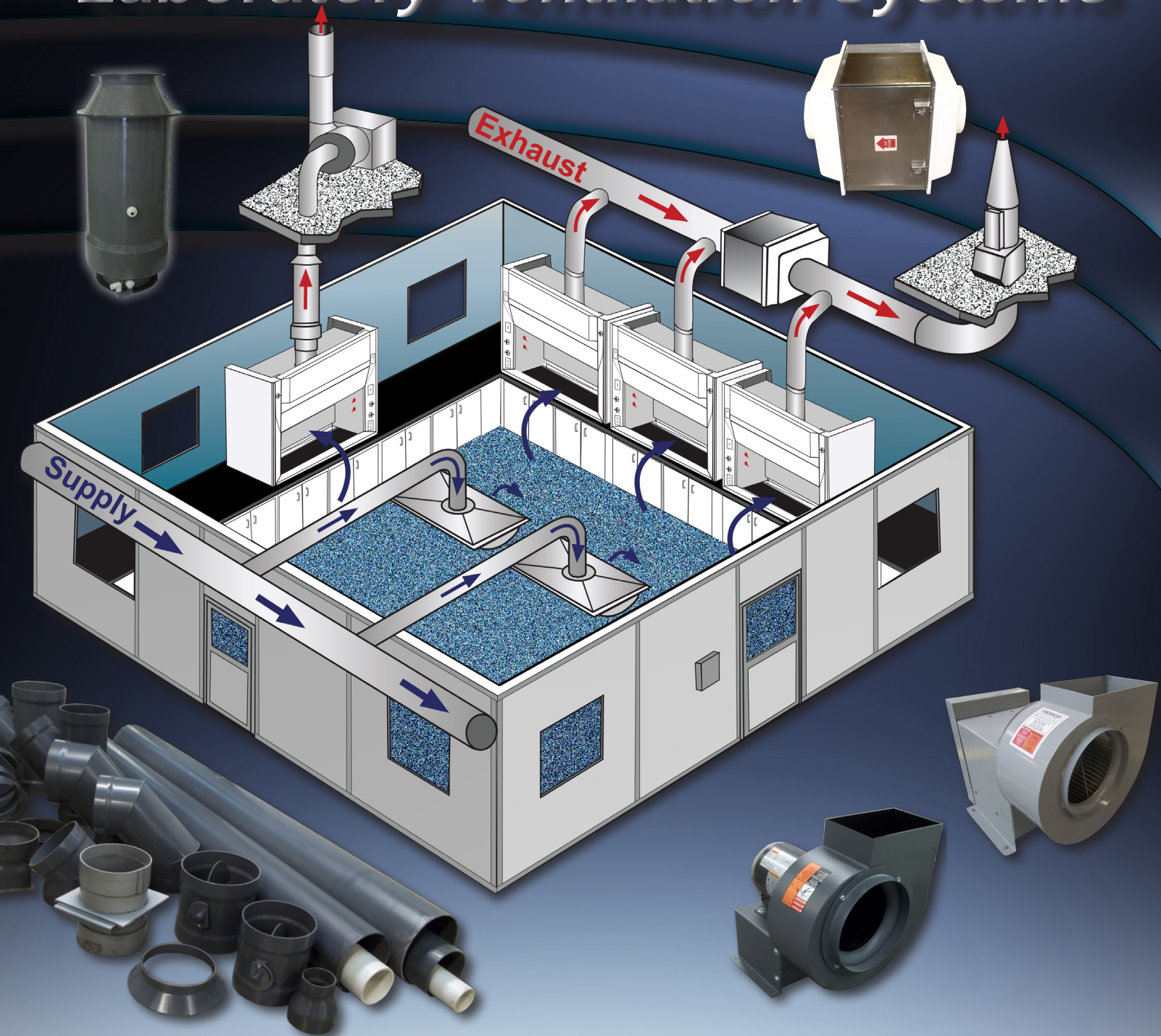

- Fume Hood Exhaust Blowers
- HEPA & Carbon Filtration
- Ducting & Exhaust
- Fume Scrubbers
- Manifolds



**HEMCO**<sup>®</sup>

ISO 9001:2015 Certified Company

# Fume Hood Ventilation and Duct Design

Ductwork connected to fume hoods may be arranged in a variety of patterns depending on requirements. Generally, the best exhaust system involves the shortest duct length and the fewest elbows. Duct size, length, and number of elbows affect static pressure loss and blower efficiency. Ideally, each fume hood should have its own ducting and blower to maximize hood flexibility and reduce danger of back draft from other hoods.

Common or manifold ductwork designs can be used, provided duct and blower have been sized properly. In these designs, individual hood dampers are recommended to balance the system. Hood users must be aware of how different hood exhaust fumes will react when mixed in the ductwork. Rigid PVC ductwork is recognized as an excellent fume hood exhaust duct material. The smooth interior surface reduces static pressure loss and chemical waste build up, and PVC is extremely resistant to a wide variety of reagents. For some applications flexible PVC lined duct provides adequate service and can significantly reduce installation costs. When planning exhaust ducting, duct size, length, number of bends, and exhaust material must be considered. Consult HEMCO for Lab Ventilation Solutions.

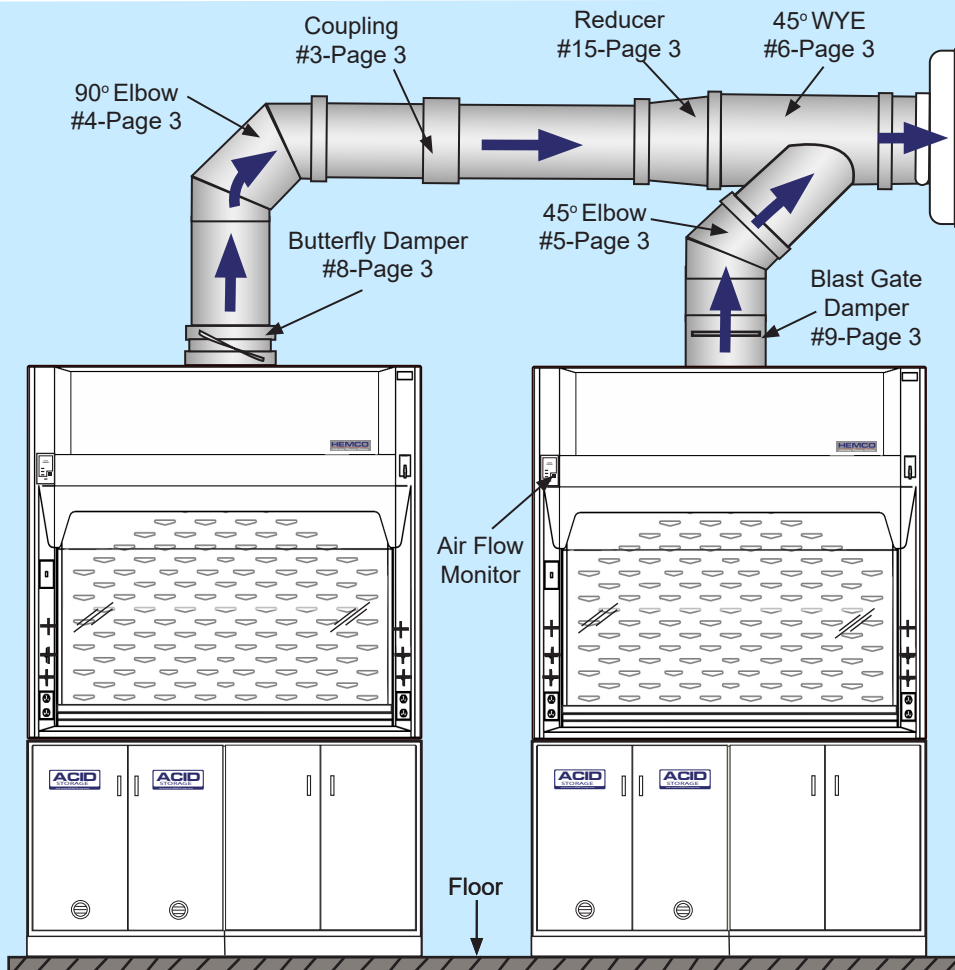
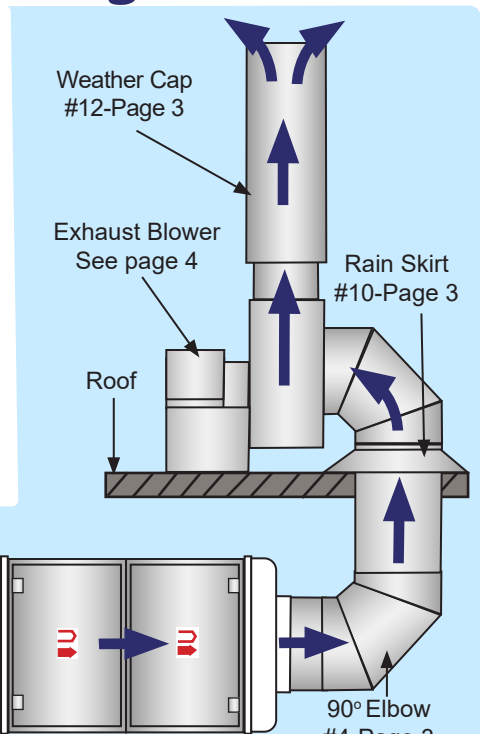

**Air Flow Monitors**  
 Note: OSHA recommends air flow alarms to be installed on all fume hoods.

**Air Flow Monitor Analog**  
 Continuously monitors face velocity air flow of fume hood. Select and calibrate at desired FPM velocity set point. If the hood face velocity falls below set point, an audible alarm sounds and a visual red indicator light appears. Air flow alarm is factory installed or can be field installed, 115/60Hz AC.  
 Cat. No. 51403

**Air Flow Monitor with Digital Display**  
 Continuously monitors face velocity air flow of fume hood. A digital display of face velocity in m/sec or FPM that indicates safety reading with an audible alarm. Push button calibration and 3 programmable input/output relays. Factory installed or can be field installed.  
 Cat. No. 51410

**Air Flow Monitor Intrinsically Safe**  
 For applications where the fume chamber is classified but the surrounding lab space is not. Continuously monitors face velocity air flow of fume hood. If the hood face velocity falls below set point, an audible alarm sounds and a visual red indicator light appears. Factory installed or can be field installed.  
 Cat. No. 51404



**Minihelic Gauge**  
 Gauge monitors the pressure across the HEPA filter. Gauge mounts on the fume hood or on the filter housing. Measure range is from 0 to 2.0" wg. accurate within 5%. Gauge is 3" dia.  
 Cat. No. 51300



**Magnehelic Gauge**  
 Gauge measures static pressure across the HEPA filter. Can mount on the fume hood or the filter housing. Range of measurement is from 0 to 2"wg. dia. accurate within 2%. Gauge is 5"  
 Cat. No. 51301



**Mini Photohelic Gauge**  
 Mini-Photohelic differential pressure gauge with two SPDT switching set points, is designed to measure and control positive, negative, or differential pressures consisting of noncombustible and non-corrosive gasses. Gauge is 3" dia.  
 Cat. No. 51302















**DigiHelic Gauge**  
 Gauge allows selection of pressure, velocity, or volumetric flow operation. Menu keys to access 5 menus which provide access to security level, selection of pressure, velocity of flow operation, and selection of engineering units. Gauge is 3" dia.  
 Cat. No. 51303

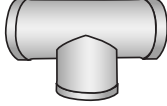

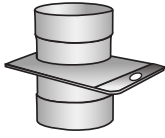
# Fume Hood Ductwork & Venting Accessories

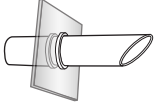
Ducting and accessories are chemical resistant and easy to install.

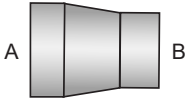
Flexible and Rigid PVC Ducting		4"	6"	8"	10"	12"	14"
	<b>1. Flexible Ducting</b> neoprene impregnated fiberglass reinforced with steel helix wire. Standard 12' lengths. Each piece includes 2 clamps	Cat. No. 80051	Cat. No. 80052	Cat. No. 80053	Cat. No. 80054	Cat. No. 80055	Cat. No. 80056
	<b>2. PVC Rigid Ducting</b> chemical resistant for permanent installations. Standard 10' lengths with straight ends.	Cat. No. 82004	Cat. No. 82006	Cat. No. 82009	Cat. No. 82011	Cat. No. 82013	Cat. No. 82015
	<b>3. PVC Coupling</b> required to connect straight sections.	Cat. No. 82147	Cat. No. 82149	Cat. No. 82153	Cat. No. 82157	Cat. No. 82159	Cat. No. 82160
	<b>4. PVC 90° Elbow</b> used in order to offset obstacles. Has belled ends for duct connections.	Cat. No. 82060	Cat. No. 82061	Cat. No. 82063	Cat. No. 82066	Cat. No. 82068	Cat. No. 82069
	<b>5. PVC 45° Elbow</b> used in order to offset obstacles. Less static pressure loss than a 90° elbow. Has belled ends for duct connections.	Cat. No. 82082	Cat. No. 82083	Cat. No. 82085	Cat. No. 82087	Cat. No. 82089	Cat. No. 82090
	<b>6. PVC 45° WYE</b> lateral for joining common ductwork in multiple hood designs. Branch diameter may be sized to 2" to 4" smaller than main diameter. Has belled ends for duct connections.	Cat. No. 82216	Cat. No. 82218	Cat. No. 82226	Cat. No. 82229	Cat. No. 82233	Cat. No. 82234
	<b>7. PVC Tee</b> used in manifold exhaust systems. Has belled ends for duct connections.	Cat. No. 82034	Cat. No. 82036	Cat. No. 82038	Cat. No. 82040	Cat. No. 82044	Cat. No. 82046
	<b>8. PVC Butterfly Damper</b> modifies CFM for single or multiple hood arrangement. Has belled ends for duct connections.	Cat. No. 82450	Cat. No. 82452	Cat. No. 82454	Cat. No. 82456	Cat. No. 82458	Cat. No. 82460
	<b>9. PVC Blast Gate Damper</b> a gate that slides in and out to control CFM. Has belled ends for duct connections.	Cat. No. 82369	Cat. No. 82371	Cat. No. 82373	Cat. No. 82375	Cat. No. 82377	Cat. No. 82379
	<b>10. PVC Rain Skirt</b> slips over straight pipe on roof to slope water away from cutout.	Cat. No. 82328	Cat. No. 82330	Cat. No. 82332	Cat. No. 82334	Cat. No. 82336	Cat. No. 82337
	<b>11. PVC Vent Outlet</b> for horizontal venting through wall or window. Angled end prevents rain from entering. Male connector included.	Cat. No. 80074	Cat. No. 80076	Cat. No. 80077	Cat. No. 80078	Cat. No. 80079	Cat. No. 80080
	<b>12. Zero Pressure Weather Cap</b> discharges fumes vertically away from roof. Self-draining. Minimal static pressure loss. This is the recommended weather cap.	Cat. No. 82350	Cat. No. 82352	Cat. No. 82354	Cat. No. 82356	Cat. No. 82358	Cat. No. 82359
	<b>13. Round to Round Transition</b> to smaller duct diameter.	Cat. No. 82613 4" - 6"	Cat. No. 82615 6" - 8"	Cat. No. 82617 8" - 10"	Cat. No. 82619 10" - 12"	Cat. No. 82620 12" - 14"	Cat. No. 82621 14" - 16"

# Fume Hood Exhaust Blowers Ordering Info

## Blower Description:

- CFM at 100 fpm face velocity
- Housing is constructed of heavy gauged galvanized steel, with a baked enamel finish, to resist weather & chemical exposures.
- Flange inlet collars enable easy connection to ductwork.
- Wheel is dynamically balanced to minimize noise and increase efficiency.
- Ball bearing pillow blocks are pre-lubricated and resistant to both moisture and dirt.
- Shaft is constructed of polished steel with a coating to prevent rust and corrosion.
- Motors meet NEMA standards for single speed motors.
- These blowers are ideally suited for both supply and exhaust applications in laboratories, educational, pharmaceutical, industrial, and other applications.

UniFlow CE Fume Hoods			
Hood Width	Hood Depth	Full Open cfm	1/2 Open cfm
30"	24"	378	189
36"	24"	460	230
48"	24"	654	327
60"	24"	1046	523
72"	24"		
UniFlow SE & LE Fume Hoods			
Hood Width	Hood Depth	Full Open cfm	1/2 Open cfm
36"	30"	438	241
48"	30"	772	385
60"	30"	938	474
72"	30"	1162	592
96"	30"	1613	800

## Blower Recommendations:

1. Blowers should be mounted on the roof in-order that the ducting leading to the blower inlet is under negative static pressure. If exhaust blowers are mounted inside the building, all ducting connected to the blower outlet will be under positive static pressure, if a leak were to develop in the section of the duct inside the building, toxic and or hazardous fumes could be forced out of the ductwork and into that area of the building.
2. To achieve the lowest practical noise level in the exhaust system, we suggest that the following measurements be used when there is no conflict with other specifications of the system:
  - a. Use vibration isolators or mounting blower exhaust assembly.
  - b. Install a blower fan that will deliver the correct CFM and static pressure with the lowest practical impeller wheel RPM. If possible, use a duct size large enough to keep duct velocity under 1800 FPM velocity.
  - c. Use a flexible connection at the fan inlet to isolate mechanical transmission of noise from the ducting between the hood and the exhaust blower.
  - d. Exhaust blower system should be designed with the fewest possible elbows or other fittings. Use radius type elbows and avoid using square elbows. Use gradual tapered transitions where necessary, and avoid abrupt changes in configuration or cross sectional area.
3. When ordering an exhaust blower, specify the orientation of discharge desired. Vertical up blast discharge is the most common and will be supplied unless otherwise specified.
4. All fans are shipped with clockwise rotation when viewed from the motor end of the assembly. Counter clockwise rotation is available on special order blowers at an increased price, but in most cases, expect 4 to 6 months wait time on shipment.
5. For normal usage with extremely corrosive fumes, it is recommended that both the blower housing and impeller wheel be FP ( fluoropolymer) coated.
6. Blowers used for hood exhaust at altitudes above 1,000 feet, may require a correction factor to provide the correct CFM and static pressure. Contact factory for details relating to your specific application.

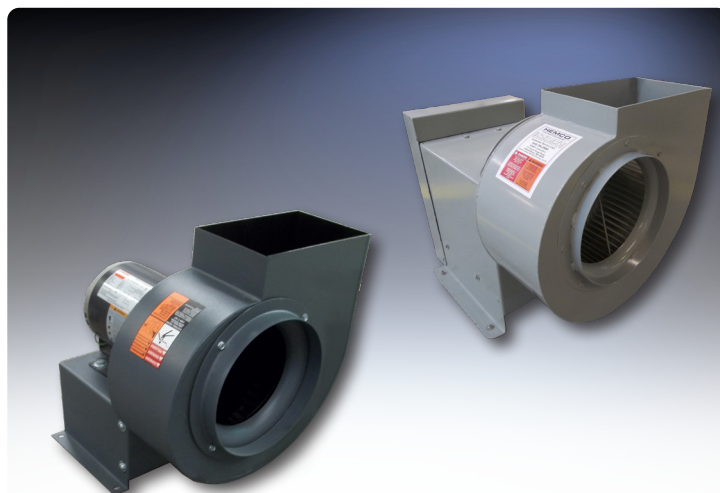



# Fume Hood Exhaust Blowers Ordering Info

A complete line of belt and direct drive exhaust blowers that are chemical resistant & available in standard and explosion-proof models. HEMCO blowers are designed to operate effectively and efficiently to remove noxious & hazardous fumes. Standard 115V 60Hz & international electrical configuration of 220V 50Hz AC available.

## Epoxy Coated Steel Blower Belt Drive

Standard (STD) belt drive steel blower and impeller wheel are epoxy coated for superior chemical resistance. Explosion-proof blowers (EXP) have epoxy coated, non-sparking aluminum impeller wheel. V-belt drive and adjustable pulleys permit field balancing. Seven discharge positions to suit installation. Weather housing is furnished. Motor has thermal overload protection. Specify: 115 V single phase, 230 V single phase, 230/460 V three phase or 208 V (consult factory). 1 year manufacturer's warranty

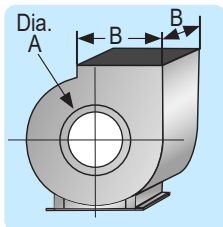

Catalog Number and Static Pressure														
cfm	A Inlet Diameter	B Outlet Size	1/2" Static Pressure			3/4" Static Pressure			1" Static Pressure			1 1/2" Static Pressure		
			HP	STD	EXP	HP	STD	EXP	HP	STD	EXP	HP	STD	EXP
296	8 7/8"	10 1/8" x 4 1/8"	1/4	51701	51801	1/4	51702	51802	1/4	51703	51803	1/4	51704	51804
474	8 7/8"	10 1/8" x 4 1/8"	1/4	51705	51805	1/4	51706	51806	1/4	51707	51807	1/2	51708	51808
652	8 7/8"	10 1/8" x 6 3/8"	1/2	51709	51809	1/2	51710	51810	1/2	51711	51811	1/2	51712	51812
800	8 7/8"	10 1/8" x 6 3/8"	1/2	51713	51813	1/2	51714	51814	1/2	51715	51815	3/4	51716	51816
914	9 7/8"	11 1/2" x 8 1/4"	1/2	51717	51817	1/2	51718	51818	—	—	—	—	—	—
1044	9 7/8"	11 1/2" x 8 1/4"	1/2	51719	51819	1/2	51720	51820	3/4	51721	51821	—	—	—
1175	9 7/8"	11 1/2" x 8 1/4"	1/2	51722	51822	1/2	51723	51823	3/4	51724	51824	—	—	—
1240	9 7/8"	11 1/2" x 8 1/4"	1/2	51725	51825	1/2	51726	51826	3/4	51727	51827	3/4	51728	51828
1240	11 7/8"	13 3/8" x 8 1/4"	1/3	51729	51829	1/2	51730	51830	—	—	—	—	—	—
1506	11 7/8"	13 3/8" x 8 1/4"	1/2	51731	51831	1/2	51732	51832	3/4	51733	51833	—	—	—
1771	11 7/8"	13 3/8" x 8 1/4"	1/2	51734	51834	3/4	51735	51835	3/4	51736	51836	1	51737	51837

## Epoxy Coated Steel Blower Direct Drive

Direct drive steel blower and impeller wheel are epoxy coated for superior chemical resistance. Explosion proof blowers have epoxy coated non-sparking aluminum impeller wheels. Motor is 115V, 1 phase and has thermal overload protection. 1 year manufacturer's warranty

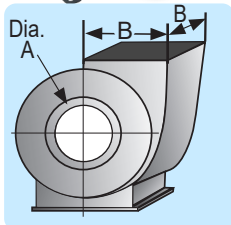
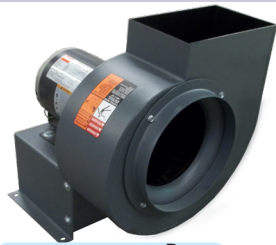

A Inlet Diameter	B Outlet Size	HP	STD	EXP	1/4" SP	1/2" SP	3/4" SP	1" SP
					cfm	cfm	cfm	cfm
6"	7" X 4-3/8"	1/6	51177	51178	565	515	440	300
8"	8-3/4" X 5-7/16"	1/3	51179	51180	935	875	800	712
9"	10-1/8" X 4-1/8"	1/2	51181	51182	1050	980	920	850
9"	10-1/8" X 5-1/8"	3/4	51183	51184	1260	1220	1180	1100

Standard motors are 115V, 60Hz / 1 phase. Explosion proof motors are 115/230V, 60Hz, 1 phase. Other voltage, hertz, and phase motors are available.

## Polypropylene Belt Drive Blowers

High efficiency impellers produce low power consumption, reduced operating costs and quiet operation. 20 forward curved blades, in fire retardant polypropylene. Non-static and oil resistant v-Belt, cast iron pulleys, adjustable pulleys available, adjustment for tensioning and belt replacement. 230V explosion proof, non-sparking, chemical resistant for hostile or hazardous environments. 115V single phase or three phase. Non-static and oil resistant v-belt, cast iron pulleys, adjustable pulleys available, adjustment for tensioning and belt replacement. 1 year manufacturer's warranty

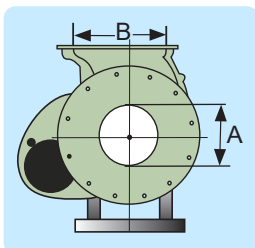

Catalog Number and Static Pressure											
cfm	A Inlet Diameter	B Outlet Diameter	0.5" Static Pressure HP			0.75" Static Pressure HP			1.0" Static Pressure HP		
			HP	STD	EXP	HP	STD	EXP	HP	STD	EXP
400	6"	6"	1/4	51450	51850	1/4	51460	51860	1/4	51470	51870
800	8"	8"	1/4	51451	51851	1/3	51461	51861	1/3	51471	51871
1000	8"	8"	1/2	51452	51852	1/2	51462	51862	1/2	51472	51872
1200	10"	10"	1/2	51453	51853	1/2	51463	51863	1/2	51473	51873
1600	10"	10"	1	51754	51854	1	51464	51864	1	51474	51874

# Sizing Fume Hood Exhaust Blowers

## Selecting a Blower:

1. Using the sizing instructions select the size blower required from the CFM static pressure charts.
2. When spark resistance is required, specify the explosion proof blower catalog number.
3. When selecting a blower to suite the operating condition, please specify the operating voltage & phase.
4. All blowers have a coated impeller wheel, the frame and housing have a baked chemical resistant, synthetic resin finish.
5. If specified a chemical resistant resin finish can be applied to the blower housing for maximum chemical resistance.
6. V-belt drive blowers are shipped with adjustable pitch motor sheaves to cover the RPM range indicated for each blower.
7. If the desired RPM and/or CFM static pressure are not specified, the blower will be shipped with an adjustable motor sheave set to the midpoint of the RPM range.
8. It is recommended that all Perchloric acid fume hoods, use the chemical resistant resin finish, on both the impeller wheel and the blower housing.

## Sizing a Blower:

1. When determining the size of a blower required for a fume hood system, both the air volume flow rate and the system static pressure must be determined. Air volume flow rate at various face velocities, in cubic feet per minute CFM, is shown on the specification page for each style and size of fume hood. The system static pressure must be calculated based on the static pressure, air flow volume rate and duct configuration.
2. A simplified method for calculating the system static pressure which gives sufficient accuracy for the small blower systems used for one or two laboratory fume hoods is listed below. This method doesn't take into account the effect that poor inlet conditions can have on a blower's performance. The effect can be minimized by using at least 5 feet of straight ductwork at the inlet of the blower and including a gradual transition to the blower inlet.
3. Determining the correct duct size. The size of duct used should be at least as large as the duct collar on the fume hood. To insure quiet operation, a duct velocity of less than 1800 feet per minute should be met. Velocities for various duct sizes & air volume flow rates are available in the duct velocity table.
4. Determine the fume hood static pressure. Fume hood static pressure can be found listed next to the air volume flow rates on the specification page for each style of fume hood.
5. Calculating static pressure loss in straight ductwork. For calculating, the length of straight ductwork should be known to within 10 feet of the actual length. Small inaccuracies in the length of duct do not affect the results. Static pressure loss per hundred feet of straight duct is given in table 2. Static pressure loss in the straight duct is equal to the length of straight duct in feet multiplied by the value from table 2, and divided by 100.
6. Calculating loss from elbows. The exact number of elbows in the system needs to be determined because it has a direct effect on the results. The values in table 3 are based on elbows with a turning radius that is 1.5 times the diameter of the duct. Elbows with a smaller turning radius should not be included as they have increased static pressure losses and generate more noise. The static pressure loss for elbows is calculated by taking the number of elbows in the system multiplied by the value from table 3.
7. Calculating loss in "WYE" connections. Table 4 supplies the static pressure loss for a "WYE" connection used on fume hoods with 2 duct collars or duct systems serving 2 fume hoods. The values in table 4 are based on "WYE"s with angles of 90 degrees. "WYE"s with angles that are larger and "T"s should not be used as they have larger pressure losses and generate more increased noise levels.
8. Calculating total for static pressure. The total system static pressure is the sum of the fume hood static pressure, the static pressure loss due to friction in the straight duct, & the static pressure losses due to change in direction & turbulence in the elbows & "WYE"s. Add the values obtained in steps 2 through 5 to calculate the total system static pressure.

cfm	10"	12"	14"	16"	18"
400	733	509			
500	917	637	468		
600	1100	764	561		
700	1283	891	655	501	
800	1467	1019	748	573	
900	1650	1146	842	645	509
1000	1833	1273	935	716	566
1100	2017	1401	1029	788	622
1200	2200	1528	1123	859	679
1300	2384	1655	1216	931	736
1400	2567	1783	1310	1003	792
1500	2750	1910	1403	1074	849
1600	2934	2037	1497	1146	905
1700		2165	1590	1218	962
1800		2292	1684	1289	1019
1900		2419	1777	1361	1075
2000		2546	1871	1432	1132
2200		2801	2058	1576	1245
2400			2245	1719	1358
2600			2432	1862	1471
2800			2806	2005	1584
3000			2993	2149	1698
3200				2292	1811
3400				2435	1924
3600				2578	2037
3800				2722	2150
4000				2865	2264

# Fume Hood Exhaust Blowers Static Pressure Info

**Table 2. Static Pressure loss per 100 ft straight run of duct by fitting diameter**

cfm	10"	12"	14"	16"	18"
400	0.09	0.04			
500	0.14	0.06	0.03		
600	0.20	0.08	0.04		
700	0.27	0.11	0.05	0.03	
800	0.34	0.14	0.06	0.03	
900	0.43	0.17	0.08	0.04	0.02
1000	0.52	0.21	0.10	0.05	0.03
1100	0.63	0.25	0.12	0.06	0.03
1200	0.74	0.30	0.14	0.07	0.04
1300	0.86	0.34	0.16	0.08	0.04
1400	0.99	0.40	0.18	0.09	0.05
1500	1.13	0.45	0.21	0.11	0.06
1600	1.28	0.51	0.24	0.12	0.07
1700		0.57	0.26	0.14	0.07
1800		0.64	0.29	0.15	0.08
1900		0.71	0.33	0.17	0.09
2000		0.78	0.36	0.18	0.10
2200		0.94	0.43	0.22	0.12
2400			0.51	0.26	0.14
2600			0.59	0.30	0.17
2800			0.68	0.35	0.19
3000			0.78	0.40	0.22
3200			0.88	0.45	0.25
3400				0.50	0.28
3600				0.56	0.31
3800				0.62	0.35
4000				0.69	0.38

**Table 3. Static Pressure loss per 90 degree elbow by fitting diameter**

cfm	10"	12"	14"	16"	18"
400	0.01	0.01			
500	0.02	0.01	0.01		
600	0.03	0.01	0.01		
700	0.04	0.02	0.01	0.01	
800	0.05	0.03	0.01	0.01	
900	0.07	0.03	0.02	0.01	0.01
1000	0.08	0.04	0.02	0.01	0.01
1100	0.10	0.05	0.03	0.02	0.01
1200	0.12	0.06	0.03	0.02	0.01
1300	0.14	0.07	0.04	0.02	0.01
1400	0.16	0.08	0.04	0.02	0.02
1500	0.18	0.09	0.05	0.03	0.02
1600	0.21	0.10	0.05	0.03	0.02
1700		0.11	0.06	0.04	0.02
1800		0.13	0.07	0.04	0.03
1900		0.14	0.08	0.05	0.03
2000		0.16	0.09	0.05	0.03
2200		0.19	0.10	0.06	0.04
2400			0.12	0.07	0.04
2600			0.14	0.08	0.05
2800			0.17	0.10	0.06
3000			0.19	0.11	0.07
3200			0.22	0.13	0.08
3400				0.14	0.09
3600				0.16	0.10
3800				0.18	0.11
4000				0.20	0.12

**Table 4. Static Pressure loss per "WYE" by fitting diameter**

cfm	12"	14"	16"	18"
800	0.05	0.03	0.01	
900	0.07	0.03	0.01	
1000	0.09	0.04	0.02	
1100	0.10	0.05	0.02	0.01
1200	0.12	0.06	0.02	0.01
1300	0.14	0.07	0.03	0.02
1400	0.17	0.08	0.03	0.02
1500	0.19	0.09	0.04	0.02
1600	0.22	0.10	0.04	0.03
1700	0.25	0.11	0.05	0.03
1800	0.28	0.13	0.05	0.03
1900	0.31	0.14	0.06	0.04
2000	0.34	0.16	0.07	0.04
2200	0.41	0.19	0.08	0.05
2400		0.23	0.10	0.06
2600		0.26	0.11	0.07
2800		0.31	0.13	0.08
3000		0.35	0.15	0.09
3200		0.40	0.17	0.10
3400			0.19	0.11
3600			0.21	0.13
3800			0.24	0.14
4000			0.27	0.16

 Color Code Blue = Increased Noise Level

 Color Code Yellow = Normal Noise Level

•The static pressure loss for 49 degree elbows is equal to 1/2 of the ratings for 90 degree elbows.

•Chart based on (2) 12" diameter ducts joining to the duct size shown. The included angel of the (2) 12" ducts is 90 degrees.

<b>UNIFLOW PERCHLORIC ACID FUME HOODS EXHAUST ORDERING DESCRIPTIONS</b>		<b>FUME HOOD WIDTH A</b>		
		<b>48" Cat.No.</b>	<b>60" Cat.No.</b>	<b>72" Cat.No.</b>
1. Blowers are constructed of fluoropolymer coated steel, are belt driven, include TEFC motors and feature a spray wash nozzle and drain in the blower housing. The specifications to the right are based on 120 Fpm face velocity.	(For 48" hoods) 475 cfm @ 1/2 open (For 48" hoods) 950 cfm @ full open	<b>52395</b> <b>51395</b>		
	(For 60" hoods) 625 cfm @ 1/2 open (For 60" hoods) 1250 cfm @ full open		<b>52396</b> <b>51396</b>	
	(For 72" hoods) 765 cfm @ 1/2 open (For 72" hoods) 1525 cfm @ full open			<b>52397</b> <b>51397</b>



# Clean Aire In-Line HEPA Filtration Systems

HEMCO HEPA Filter Paks effectively collect particulate contaminants from the exhaust air stream. HEPA filters are 99.999% effective at removing particulate .3 micron and larger. The filter pak housing features a hinged access door with gaskets and spring latches for convenient filter change. Inlet and outlet plenums with duct connection collars are installed. The HEPA Filter Pak can also be paired with a carbon filter pak to remove chemical fumes and odors.

## Clean Aire In-Line HEPA Filtration Systems

Note: HEMCO recommends a minihelic or magnehelic gauge to monitor the air flow differential across the filter. The static pressure indicated would alert when to change filter. The gauges can be hood or filter mounted. We recommend ordering a back-up replacement filter.

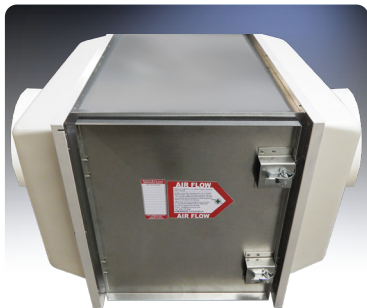

Clean Aire HEPA Filter Pak					
CFM	Size		Duct Size	Cat. No.	
250-650	26" x 15" x 35 1/2"		4", 6", 8" diameter	<b>50188</b>	
650-1200	26" x 26" x 35 1/2"		8", 10", 12" diameter	<b>50189</b>	
HEPA Filters			Prefilter (6 per carton)		
CFM	Size	Cat. No.	CFM	Size	Cat. No.
500	24" x 12" x 12"	<b>50094</b>	500	24" x 12" x 2"	<b>52000</b>
1000	24" x 24" x 12"	<b>50095</b>	1000	24" x 24" x 2"	<b>52001</b>

## HEPA Bag In-Bag Out Systems

**Filter Housing is fabricated of type 304 stainless steel and requires (1) HEPA filter absorber, (1) 24" X 24" X 2" 30% pleated prefilter and (1) bag.**

Bag-In bag-out filters are designed to meet air filtration requirements to handle hazardous fumes and vapors. The housing incorporates a ribbed bagging ring around the side access door over which a specially designed plastic bag is attached. Filters are then installed and changed through the bag to reduce the risk of exposure to personnel. Note: The carbon filter is not included with the housing. We also, recommend the sampling kit below to check if there has been a break through in the carbon filter, and ordering a back-up replacement filter.



Clean Aire HEPA Filter Bag-In Bag-Out System				
Description	CFM	Size	Cat. No.	
Clean-Aire HEPA Filter Bag-In Bag-out System	1000	26" X 26" X 35-1/2"	<b>51189</b>	
HEPA Filters	1000	24" X 24" X 12"	<b>50195</b>	
HEPA Prefilter ( 6 per carton)	1000	24" X 24" X 2"	<b>52001</b>	
Replacement Bags (2 per carton)			<b>51989</b>	

## Clean Aire In-Line Bag-In / Bag-Out Filtration Systems (BIBO)

**The filtration system is rated at 1800 CFM and includes a stainless steel housing with lift off and gasketed access doors for filter change-out and inlet and outlet plenums with duct connection collars sized to meet specification. Bubble tight dampers allow system to close off for filter change.**

- Initial filters supplied (excludes prefilters)
- Initial change out bags supplied.
- Inlet/outlet duct connection flanges shall be a minimum of 1-1/2" wide.
- Approx. shipping weight: 1100 LBS. (without filters)
- Approx. operating weight: 1350 LBS.
- A minimum of four (4) feet of clearance in front of access door is recommended for filter change-out.

**Cat. No. 58998-1** (1) HEPA and Carbon Inline

**Cat. No. 58998-2** (2) HEPA and Carbon InLine



# Clean Air In-Line Carbon Filtration Systems

HEMCO Carbon Filter Paks are used in laboratory exhaust and supply systems to remove chemical odors and vapors from the airstream. Filters are loaded with virgin coconut activated carbon to efficiently absorb organic solvents and acid fumes. The filter pak housing features a hinged access door with gaskets and spring latches for convenient filter changes. Inlet and outlet plenums with duct connection collars are installed. The carbon filter pak can also be paired with a HEPA Filter Pak to collect particulate contaminants.

## Clean Air In-Line Carbon Filtration Systems

Note: A standard "01" activated carbon filter for organics is included. HEMCO recommends the sampling kit to check if there has been a breakthrough in the carbon filter, and ordering a back-up replacement filter.

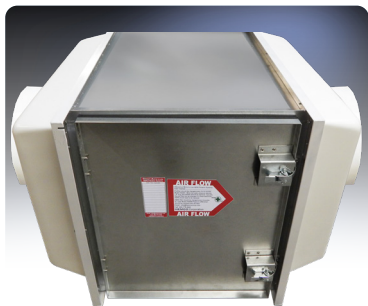

Clean Air Carbon Filter Pak					
CFM	Size		Duct Size	Cat. No.	
250-650	26" x 15" x 35 1/2"		4", 6", 8" diameter	50297	
650-1200	26" x 26" x 35 1/2"		8", 10", 12" diameter	50298	
Carbon Filters			Prefilter (6 per carton)		
CFM	Size	Cat. No.	CFM	Size	Cat. No.
500	24" x 12" x 12"	52100	500	24" x 12" x 2"	52000
1000	24" x 24" x 12"	52101	1000	24" x 24" x 2"	52001

## Carbon Bag In-Bag Out Systems

**Filter housing is fabricated of type 304 stainless steel and requires (1) carbon filter absorber, (1) 24" X 24" X 2" 30% pleated prefilter and (1) bag.**

Bag-In bag-out filters are designed to meet air filtration requirements to handle hazardous fumes and vapors. The housing incorporates a ribbed bagging ring around the side access door over which a specially designed plastic bag is attached. Old filter is removed then new filters are then installed and changed through the bag to reduce the risk of exposure to personnel. Note: The carbon filter is not included with the housing. We also, recommend a sampling kit to check if there has been a break through in the carbon filter, and ordering a back-up replacement filter.



Clean Air Carbon Filter Bag-In Bag-Out System				
Description	CFM	Size	Cat. No.	
Clean-Aire Carbon Filter Bag-In Bag-out System	1000	26" X 26" X 35-1/2"	51198	
Carbon Filters	1000	24" X 24" X 12"	52111	
Carbon Prefilter ( 6 per carton)	1000	24" X 24" X 2"	50001	
Replacement Bags (2 per carton)			51999	

## Radioisotope Bag In-Bag Out Filtration System

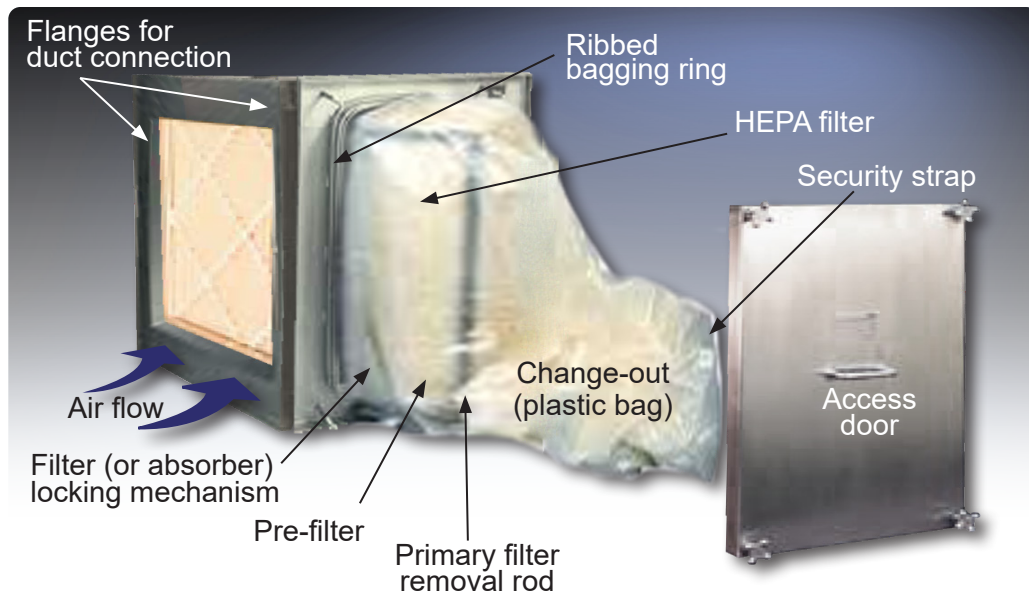

### Gas Monitor

Gas Monitor detects and warns of high concentrations of dangerous gases such as chlorinated solvents, ammonia, ethylene oxide, etc. Unit has visual and audio alarm and is factory calibrated to specific gas. 115V and power cord. Specify gas and alarm level.

Cat.No. 51400

# Fume Hood Exhaust System Diagrams

**UniFlow SE Aire Stream, LE, CE, Fume Hood Diagram**

- Standard composite fiberglass fume hood for acids or solvent fumes
- Typical exhaust blower is epoxy coated steel
- Roof mount location is recommended
- Ducting can be PVC, galvanized steel, or stainless steel
- Optional airflow alarm

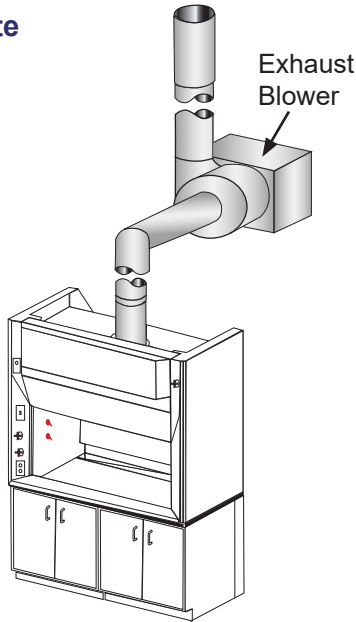

**Auxiliary Air Fume Hood Diagram**

- Standard composite fiberglass fume hood with supply air plenum
- Designed to makeup 50% of exhaust volume
- When sash is up, air enters sash opening. When sash is down air enters through upper and lower bypass
- It may be necessary to cool or heat makeup air
- Do not locate supply near the exhaust

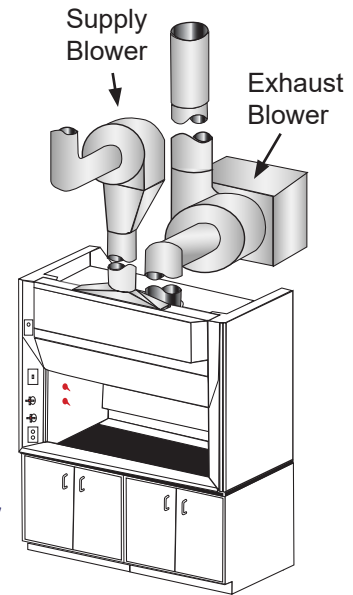

**Radioisotope Fume Hood Diagram**

- Fume hood interior to be seamless type 304 stainless steel
- Reinforced worksurface
- A bag-In-Bag-Out HEPA or carbon filter is recommended on the exhaust
- Optional magnehelic gauge to monitor HEPA filter
- Airflow monitor is recommended

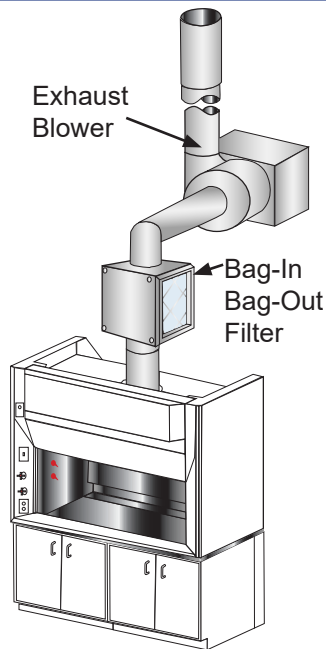

**Perchloric Acid Fume Hood Diagram**

- Fume hood interior to be seamless PVC or type 316 stainless steel
- Wash down system in fume hood ducting and blower
- Exhaust blower shall be fluoreopolymer coated
- Ducting to be as straight vertical and short as possible
- Ducting can be PVC, or stainless steel
- Airflow monitor is recommended

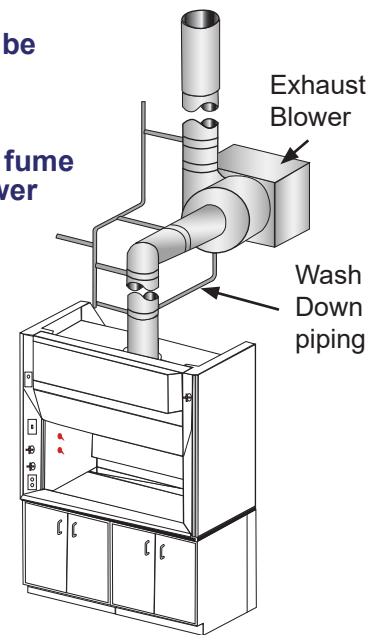

## Typical Ventilation Installation Options

Roof-mounted remote blower with vertical discharge	Wall-mounted remote blower with vertical roof discharge.	Ceiling-suspended remote blower vented through wall with vertical discharge.	Ceiling-suspended remote blower vented through wall with horizontal discharge	Internally-mount blower with vertical roof discharge.



# Laboratory Ventilation Systems

Designed to offer the complete solution to laboratory ventilation concerns. Integrated components, blowers, fume scrubbers, and ducting are engineered together to provide a safe, effective, and efficient fume hood ventilation system. VAV controllers minimize the amount of conditioned air that is exhausted through the fume hood.

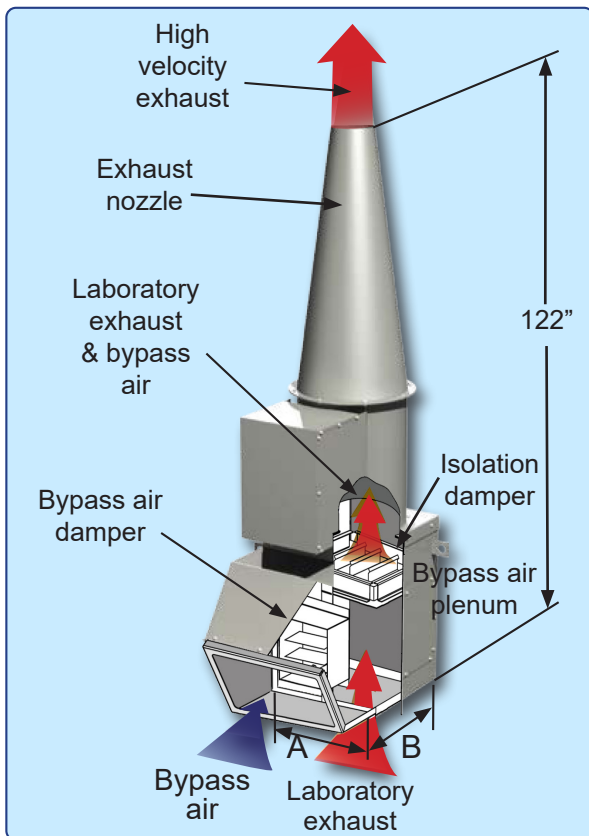
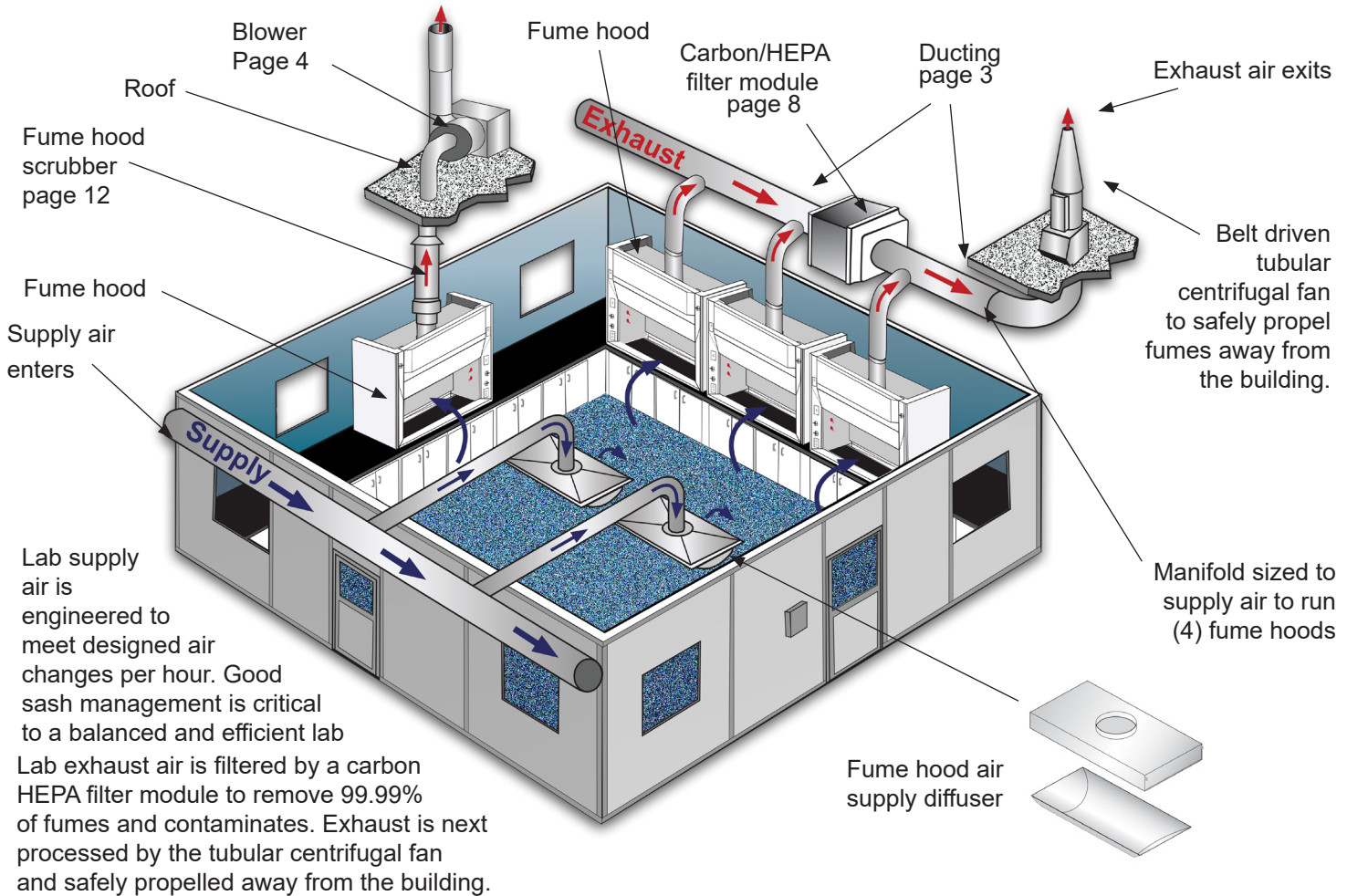

## Manifold Laboratory Exhaust Systems

- Installed quickly and easily on reinforced roof curb
- Designed to withstand up to 125 mph wind loads with out guide wires
- Performance capacities range from 270 - 2400 cfm and up to 3.5 in. wg per fan
- Meets ANSI Z9.5 , NFPA 45 and ASHRAE guidelines
- U.L. listed for electrical 705 power ventilators
- AMCA certified for sound and air performance AMCA 210 & 300
- Components are electrostatically powder coated with a 2 part corrosion resistant coating, standard color: gray
- Housing style is an in-line configuration
- 1 Year Warranty ✓

Cat. No.	Dimensions In Inches		Performance Range (cfm)		Nozzle Size Range	
	A	B	Min	Max	Min	Max
85009	21 5/8	21 5/8	270	1750	4	9
85010	21 5/8	21 5/8	450	1800	5	10
85012	21 5/8	21 5/8	600	2640	6	13
85013	23 5/8	23 5/8	810	3160	7	14
85016	27 5/8	27 5/8	---	7080	8	18

# Polypropylene Fume Hood Scrubbers

Fume Hood Scrubber is designed for laboratories that require removal of acid vapors from exhausted air, under the most demanding corrosive environmental conditions. These Scrubbers are compact vertical venturi units for indoor installations only.

- Low operating cost
- Sizes from 8" to 20", larger sizes available
- Highly effective for water soluble acids
- No moving parts to wear out or replace
- Installs directly into exiting duct systems
- Average installation time 2 hours with minimal tools
- Uses no packing material to clog or replace
- Allows the isolation of individual hoods or tanks that require pollution reduction
- Low water consumption at a minimum 8 gallons per hour
- Can be ducted if necessary to meet venting requirements
- Designed to clean up fume hood exhaust fumes.



*The design of the inline fume scrubber is based on the need for a simple, compact, efficient, and water conservative apparatus for the removal of particulates and water soluble vapors from individual laboratory fume hoods.*

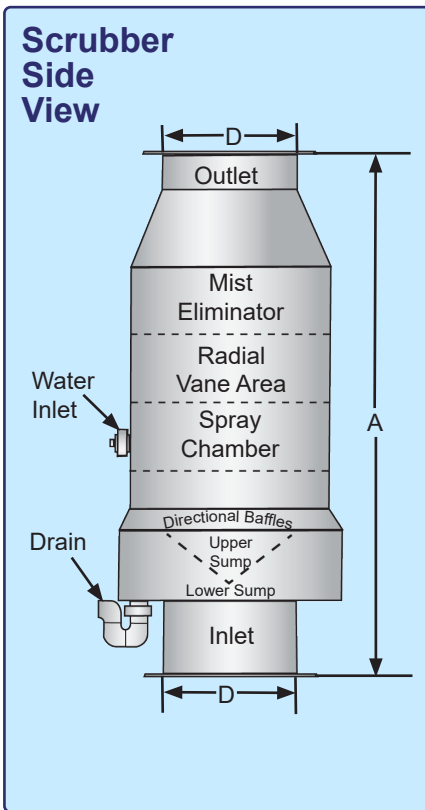

## Typical Fume Hood Installation:

Can be manifolded for 2 - 4 fume hoods depending on hood size.

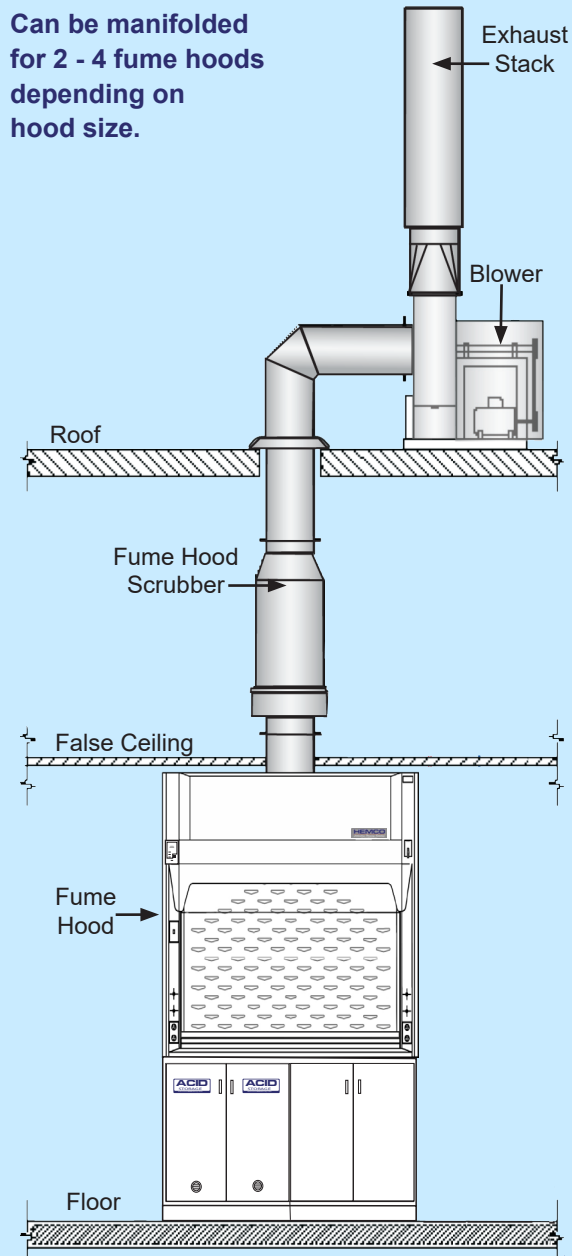

Recirculation System						
Optimal Air Volume	240-250 CFM	580-720 CFM	890-1000 CFM	1590-1735 CFM	1950-2400 CFM	2400-3052 CFM
Overall Height "A"	38.75"	44.77"	50.75"	61.75"	73.537"	78.5"
Inlet Diameter "D"	8"	10"	12"	15"	18"	20"
Cat. No.	Cat. No.	Cat. No.	Cat. No.	Cat. No.	Cat. No.	Cat. No.
PolyPro Construction	85008	85010	85012	85015	85016	85018

# Clean Air Fume Hood Scrubbers

Scrubber systems offer high efficiency & minimal maintenance on meeting pollution control requirements. Can be manifolded for 5 - 10 fume hoods exhaust.



## Remote Recirculation Pump

Can be supplied for installations where the scrubber is located outdoors and the possibility of freezing is present.

CFM	Cat. No
500	80210
1000	80211
2000	80212
4000	80213
6000	80214
8000	80215



**Fume Scrubbers** provide excellent air pollution control for water soluble fumes and odors by moving contaminated air through a filter pack media exposing over forty square feet of surface per cubic foot. Containment is collected on filter media surface and rinsed off with water, excess water is then mechanically removed and cleaned air is released. When conditions require, chemical additives can increase absorptive capacity of the scrubber. Unit includes integral recirculation tank and pump which significantly reduces water consumption and related waste disposal costs. Fan is not included, must be sized to meet exhaust requirements. Request a Plan-A Scrubber specification sheet for planning your scrubber. Designed to clean up fume hood exhaust fumes.

## PH Control Package

Allows precise control over effluent quality and provides neutralization of contaminants. The PH control system consists of a weather tight, corrosion-proof enclosure containing an analyzer, pre-wired chemical feed pump, weather-protected terminal block, clear PVC face plate and external chemical-feed connection. Enclosure can be mounted on any vertical surface. A heavy-duty industrial probe with a 10" lead wire is supplied, along with (2) 10" lengths of vinyl tubing to connect the feed pump.



Cat. No. 80112

Atmospheric Contaminant	Catalog Number and Fume Removal Efficiencies (based on a 3 foot Bed)	
	5 Foot Bed Series	With pH Control Package
Acetic Acid Mist	NR	90-95%
Alcohols	*	*
Alkaline Mists, General	99.9%	99.9%
Aqua Regina Gas	95-98%	96-98%
Ammonia Gas	NR	98-99%
Chlorine	NR	95-98%
Chromic Acid	99%	99%
Cyanide Solutions	99.9%	99.9%
Fluoborate Mist	99%	99%
Formaldehyde	NR	98-99%
Haldid Mist	98%	98%
Hydrofluoric Acid	96-99%	98-99%
Hydrogen Cyanide	NR	95-98%
Nickle Sulfate	99%	99%
Nitrogen Dioxide	*	*
Perchloric Acid	85-90%	95-98%
Phosphoric Acid	85-90%	95-98%
Sodium Sulfide	99%	99%
Sulfamate Mist	99%	99%
Sulfuric Acid	99.9%	99.9%
Zinc Chloride	95%	95%

The above efficiencies are intended as a guide representing average values. Specific combinations and concentrations of fumes may result in a significant variation from the above. \* Requires extended packing depth and chemical addition to scrubber solution.

## Horizontal Air Flow Scrubber

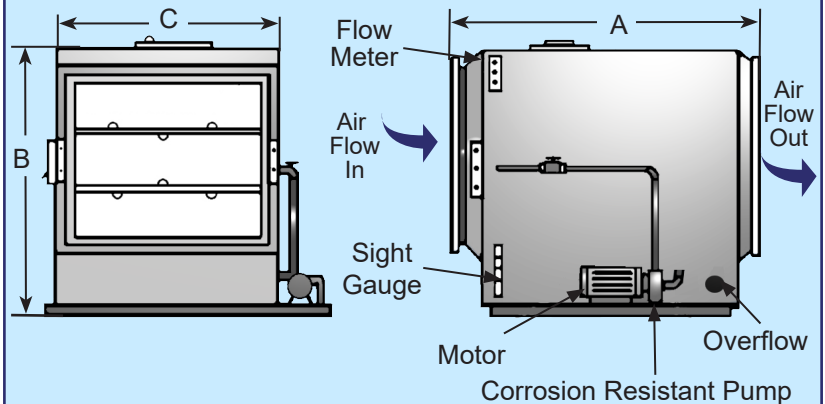

Size	Scrubber			Cat.No.	Blower	
	A	B	C		Size	Cat.No.
500 CFM	49"	30"	18"	80000	500 CFM	80010
1000 CFM	50"	34"	22"	80001	1000 CFM	80011
2000 CFM	50"	40"	28"	80002	2000 CFM	80012
3700 CFM	52"	49"	37"	80003	3700 CFM	80013
6000 CFM	53"	58"	45"	80004	6000 CFM	80014
8000 CFM	54"	65"	52"	80005	8000 CFM	80015



# Fume Hood Radial Flow Air Diffusers

The Radial Flow diffuser is designed to dilute airborne contaminants by supplying high-volume, low-velocity airflow to displace impurities. Designed to produce a uniform airflow pattern to prevent room dead spots where contaminants can linger.

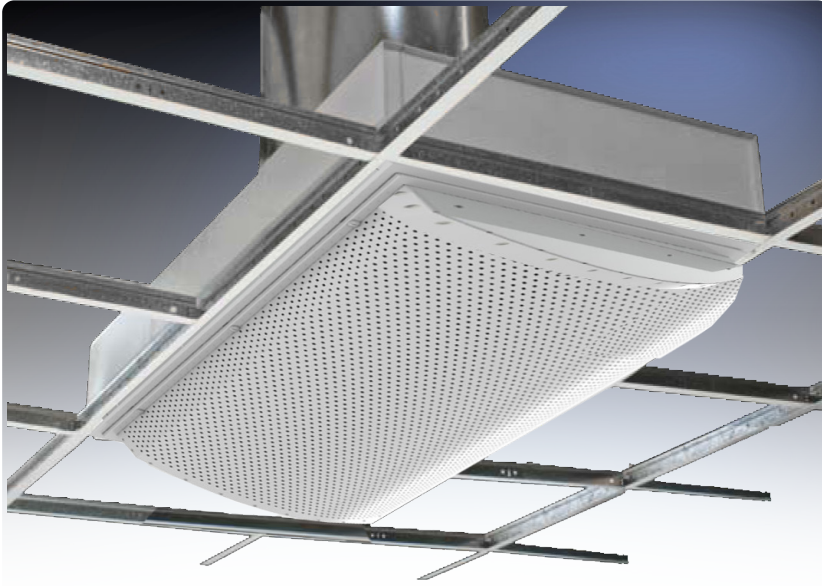

Room-side removable face for ease of cleaning (no special tools required).

Sizes available include 24 x 24 inch & 48 x 24 inch with one way or two way air flow patterns.

Available in 304 stainless steel and/or aluminum components, (face and back pan can be made of different materials).

Retainer cables and quarter-turn fasteners allow for easy access to cleaning and filter replacement.

Available duct sizes: 8 or 10 inches for 24 x 24 inch models, and 10 or 12 inches for 48 x 24 inch models.

Designed for use with 1 or 1½ inch T-bar ceiling grids, optional surface mounting frame available. Baffling inside of diffuser insures even air distribution across the entire face of the diffuser.

## Radial Flow Air Diffuser Description:

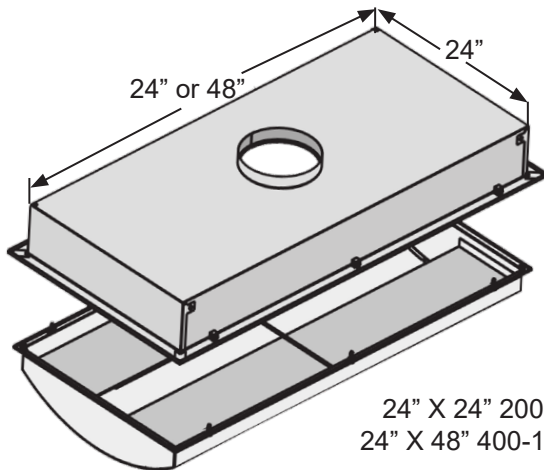

24" X 24" 200-500 cfm  
24" X 48" 400-1,000 cfm

Typical applications include labs with exhaust fans, pharmaceutical manufacturing, biotechnology and environments where high air volume with a short flow are specified.

The radial diffuser's high induction rate draws contaminants into its airstream, allowing contaminants to be diluted to less harmful levels prior to exhausting the contaminated air.

Can be used for class 1,000 to class 100,000 rooms.

## Diffuser features:

Special perforated face produces a low initial face velocity, while the shape and internal baffles distribute large volumes of air.

This allows the diffuser to flush a room with large volumes of low velocity, conditioned air while minimizing mixing with possibly contaminated air.

The face of the diffuser is connected to the back pan with a hinge.

Color: white

24" X 24" Cat.No 90011  
24" X 48" Cat.No 90012

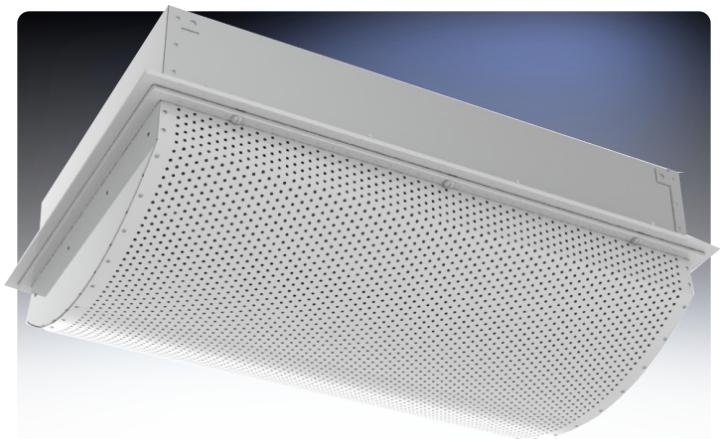

# VAV Variable Air Volume Systems

HEMCO offers sash sensing, pressure independent venturi air valves, & volumetric room flow controls for YAY applications. figure1 shows a lab with variable air volume components.

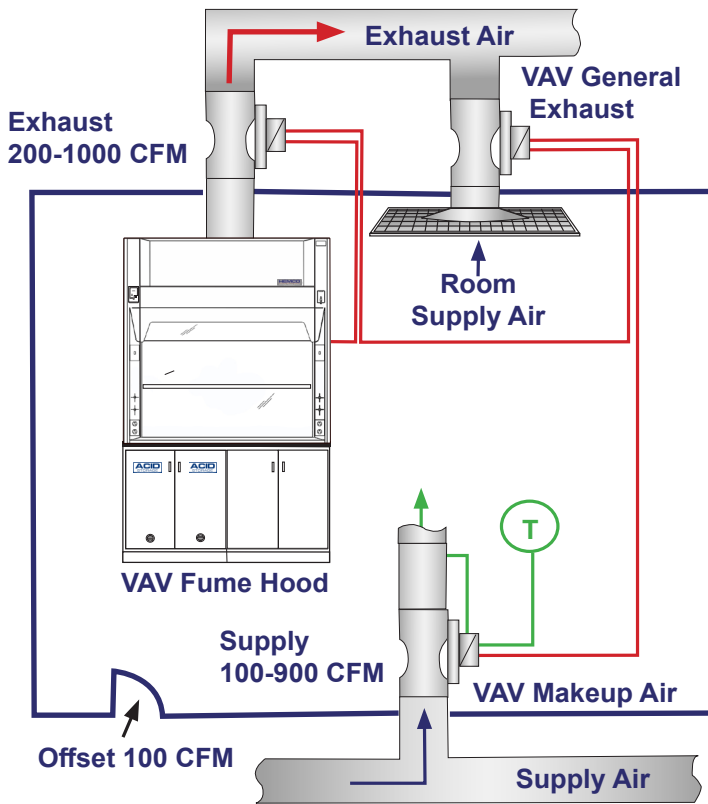

Figure 1 Variable air volume application with controls.

Pressure-independent air valves maintain proper flows over the entire range of command.

Sash opening determines flow requirements through the hood while the room make-up air is adjusted to maintain proper pressurization.

When additional air is required due to ventilation or thermal requirements, the general exhaust and make-up air valves adjust to requirements.

Fume hood monitor provides continuous monitoring of air volume, to meet regulatory requirements.

- Fast flow control with, stable adjustments over large flow changes.
- Minimal maintenance required.
- Pressure independent system maintains steady flow through air changes, HYAC degradation, and filter loading, eliminating the need for re-balancing.
- Sound power levels remain low.
- Valves used in variable volume systems provide the benefits listed above, although, the disadvantages of not closing sashes still remain.

Variable Air Volume with UBC (usage based controls) provides an intelligent form of variable volume control for fumehoods. UBC eliminates the disadvantages of not closing sashes, but still maintains safe face velocity levels while minimizing the HVAC burden. The concept is: use a higher face velocity when an operator is in front of the hood creating turbulence, but reduce the air flow to a safe level when operator is not using the fume hood. Figure 2 represents a typical UBC system. Room pressure is maintained by adjusting the make up air at a lower rate than the exhaust. Minimum ventilation and proper temperature control may require the use of a general exhaust valve, where the exhaust air rate is increased to overcome the added supply requirements.

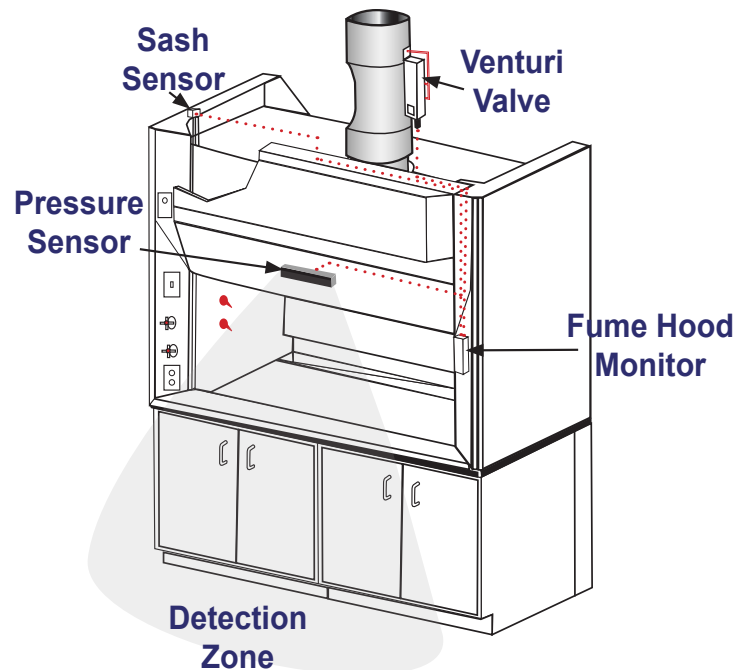

Figure 2

Variable volume application with Usage Based Controls.

- The hood operates at the lowest flow possible to maintain safe face velocities.
- When a user approaches the hood, the zone presence sensor increases the flow to provide proper containment.
- As the user exits the hood, the flow is reset to the lower, yet safe, flow. The fume hood monitor provides continuous air flow monitoring.
- Sizing of mechanical equipment based on partial load-is improved.
- HVAC costs are reduced, by assuring reductions in airflow, even when sashes are left open.
- Lower energy costs.
- Lab safety is improved due to the reduction in supply air currents that often affect fume hood containment.



**Most Extensive Line of Laboratory Fume Hoods in the Industry**  
**Reduce Energy costs up to 50% with HEMCO Sash Management 1-2-3,**  
**which provides maximum energy efficiency and user protection.**



# UniFlow

**Laboratory Fume Hoods are available in**

1. Constant Air Volume CAV Air By-Pass
2. Variable Air Volume VAV Restricted Bypass
3. Explosion Proof models for Hazardous Locations
4. CE models for International Electronic Configurations



Standard Bench Mount and Floor Mount hoods with over 40 standard sizes and custom sizes to your specs. UniFlow Superstructure exclusive unitized dual wall construction for total chemical resistance, strength, and durability. Performance tested to ASHRAE 110 - 1995. U.L.1805 Classified for Fume Hoods & Cabinets, and SEFA1 Recommended Practices for Fume Hoods.

Request a free brochure At [www.HEMCOcorp.com](http://www.HEMCOcorp.com) and browse the entire selection of HEMCO Laboratory Equipment



**Lab Planning Solutions**  
**Complete Laboratory**  
**Planning Guide**



**UniMax Large**  
**Floor Mount Walk-In**  
**Fume Hoods Brochure**



**EnviroMax Enclosures for**  
**Robotic and Automated**  
**Lab Processes**



**Modular Clean Labs**  
**& Quality Control Labs**  
**Brochure**



**HEMCO Corporation**  
**711 S. Powell Road**  
**Independence, MO 64056**

**Specify UniFlow Fume Hoods**  
**on Your Next Lab Project**

**HEMCO**  
**Laboratory Planning Solutions**



**Phone (816) 796-2900**  
**[www.HEMCOcorp.com](http://www.HEMCOcorp.com)**  
**VENT-01.24**